

**EP**  
Sales, Inc.  
(952)-854-4400  
www.epsalesinc.com

Represented By:  
**EP Sales, Inc.**  
7878 12th Avenue South  
Bloomington, MN 55425  
Phone (952) 854-4400 Fax (952) 854-4441

**EPS**  
Make-Up Air

# Make-Up Air / Preheat Kits

Effective  
**7.01.11**

Kit Model #	MA250	MA500	MA700	MA950	MA1350
<b>CFM @ .25" ESP</b>	250	458	680	932	1360
<b>Duct Size:</b>	6" round	8" round	10" round	12" round	14" round

### Fan Specs:

<b>CFM @ .25" ESP, High Speed</b>	250	458	680	932	1360
<b>CFM @ .25" ESP, Low Speed</b>	163	373	418	545	N/A
<b>Power Requirement</b>	120/1	120/1	120/1	120/1	120/1
<b>Model #</b>	TD150	TD200	TD250	TD315	PV355
<b>Amps</b>	0.5	1.5	2.0	2.8	3.3

### Heater Specs:

<b>Approx. Temperature Rise</b>	71°F	71°F	71°F	71°F	71°F
<b>Heater kW</b>	5	10	15	22	30
<b>Stages</b>	1	2	2	2	2
<b>Power Requirement</b>	240/1 ph	240/1 ph	240/1 ph	240/1 ph	240/1 ph
<b>Amps</b>	25	42	63	92	125

### Damper Specs:

<b>Power Requirement</b>	120/1 ph	120/1 ph	120/1 ph	120/1 ph	120/1 ph
<b>Model #</b>	ADC-6/120ES	ADC-8/120ES	ADC-10/120ES	ADC-12/120ES	ADC-14/120ES

**Make-up Air Kit includes:** framed washable fresh air filter, current sensing relay, motorized damper with end switch, make-up air fan and electric heater with air flow sensor & duct stat.

**Installation / Sequence of Operation:** Exhaust fan is interlocked to motorized damper with current sensing relay. Make-up air fan is interlocked to motorized damper end switch. When exhaust fan is energized and current sensing relay proves fan operation, motorized damper opens, closing end switch which energizes make-up air fan. Electric coil pre-heater will energize and temper make-up air when it senses air flow and air temperature below duct stat(s) setting.

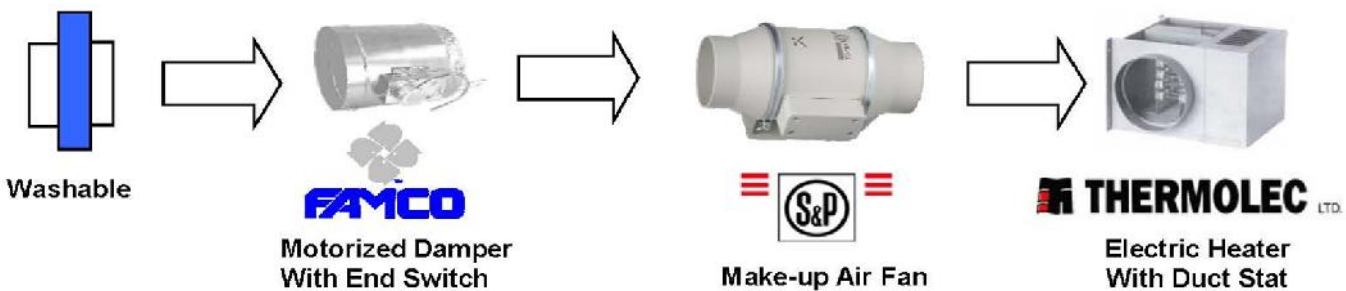

Custom sizes available upon request

# Make-up Air Kit Instructions:

Kit includes: washable filter and frame, current sensing relay, motorized damper with end switch, make-up air fan, electric pre-heater with pressure switch and duct stat(s).

Installer provided components: weather hood or louver, insulated ductwork, circuit breakers and electrical protection per local codes.

## Installation:

- Begin by installing a weather hood or louver (equal to the duct size of the MUA Kit being installed) on the exterior of the building.
- Insulated ductwork (equal to the size of the MUA Kit components) is used to supply air from the weather hood or louver to the filter, motorized damper, fan and heater as show in the diagram below.
- Install duct heater pressure switch pitot tube into ductwork and connect tubing to switch.
- Install each component per instructions.

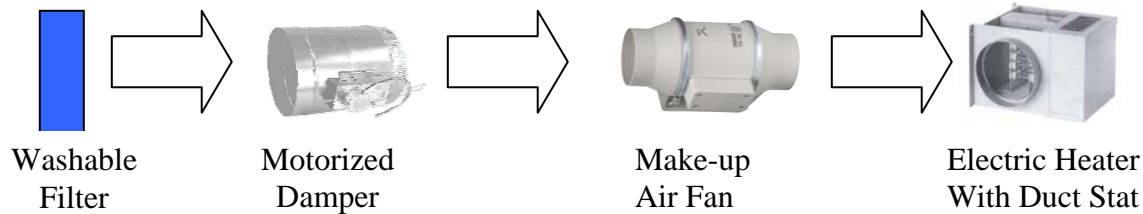

## Wiring:

- Install the current sensing relay per instructions at the exhaust fan to prove its operation.
- A 120V/1 circuit is run from the electrical panel, through the contacts of the current sensing relay, to the motorized damper (see wiring diagram included with damper).
- A 120V/1 circuit is run from the electrical panel, through the end switch of the motorized damper, to the make-up air fan (see wiring diagram included with fan).
- A 240V/1 circuit is run from the electrical panel to the electric heater (see heater wiring diagram).
- Duct stat(s) temperature sensing bulb is installed in the duct before the heater and wired to the thermostat contacts in the heater (see diagram with stat).
- For single stage heaters, set stat at 50°F. For two stage heaters set first stage at 50°F, set second stage at 10°F.

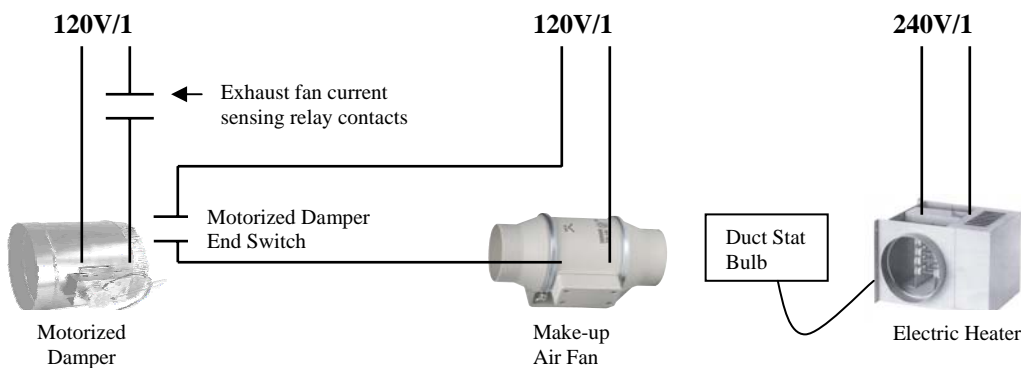

## Stat to Heater Wiring:

- First stage (or single stage stat)
- Connect Red (common) on stat to "C" on heater
  - Connect Blue on stat to "1" on heater
- Second Stage
- Connect Red (common) on stat to "C" on heater
  - Connect Blue on stat to "2" on heater

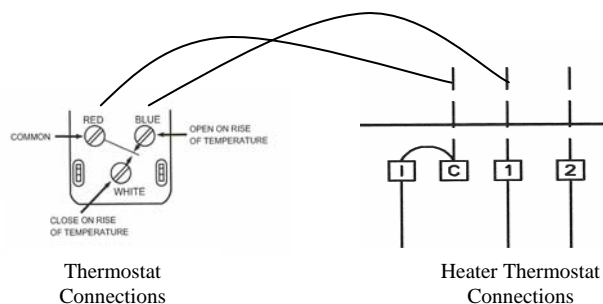

# MA-1350 Make-up Air Kit

## Electric Duct Heater Dimensions

H: 14"  
W: 14"  
T: 18"  
C: 6.5"  
X: 26"  
D: 8"

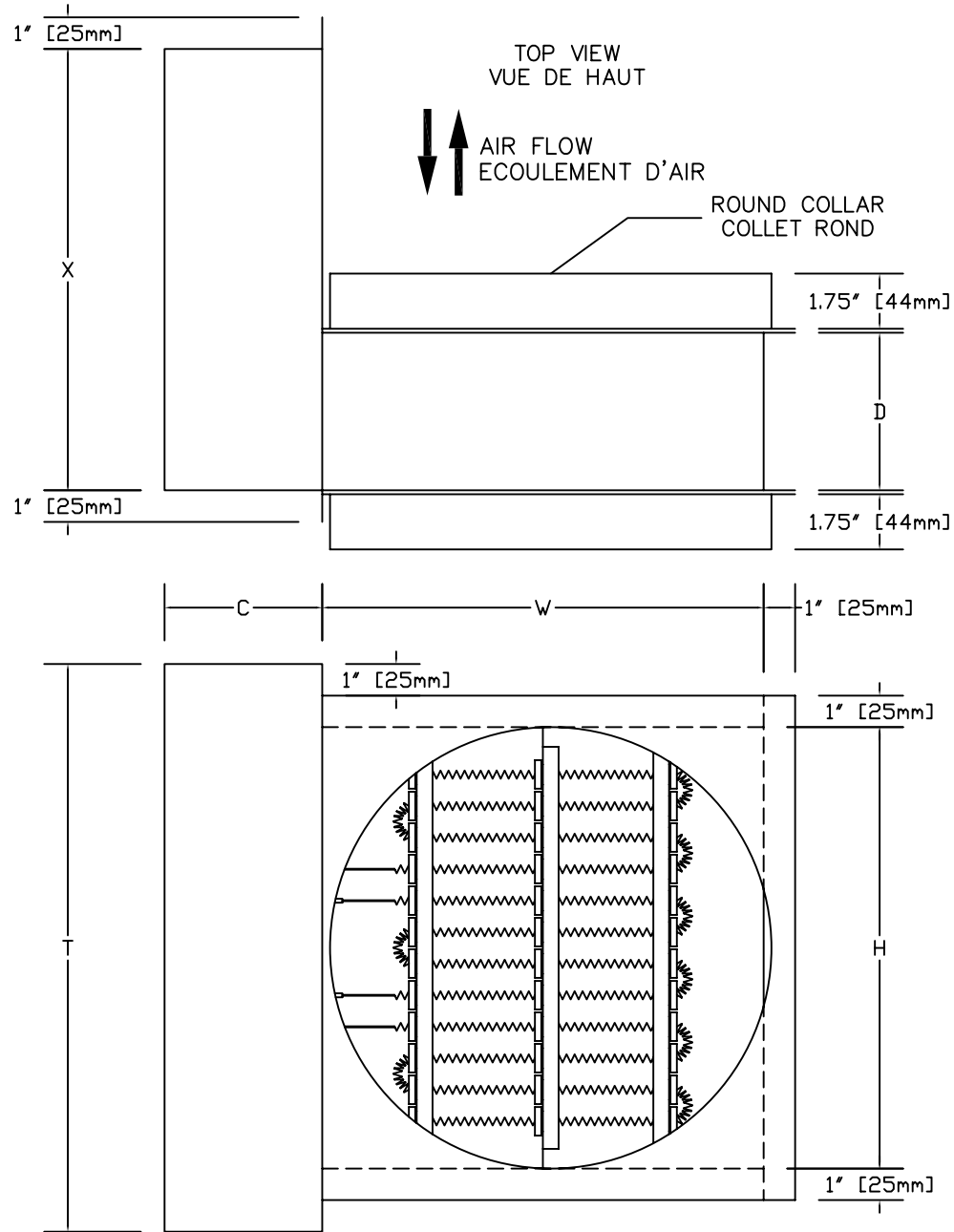

TITLE/TITRE  
TYPICAL FLANGED ROUND COLLAR HEATER  
SERPENTIN TYPIQUE A COLLET ROND



**THERMOLEC**  
MONTREAL - CANADA

LTEE  
LTD

DRAWING NO. MRFC-40LS-0002-0000

DATE

PER

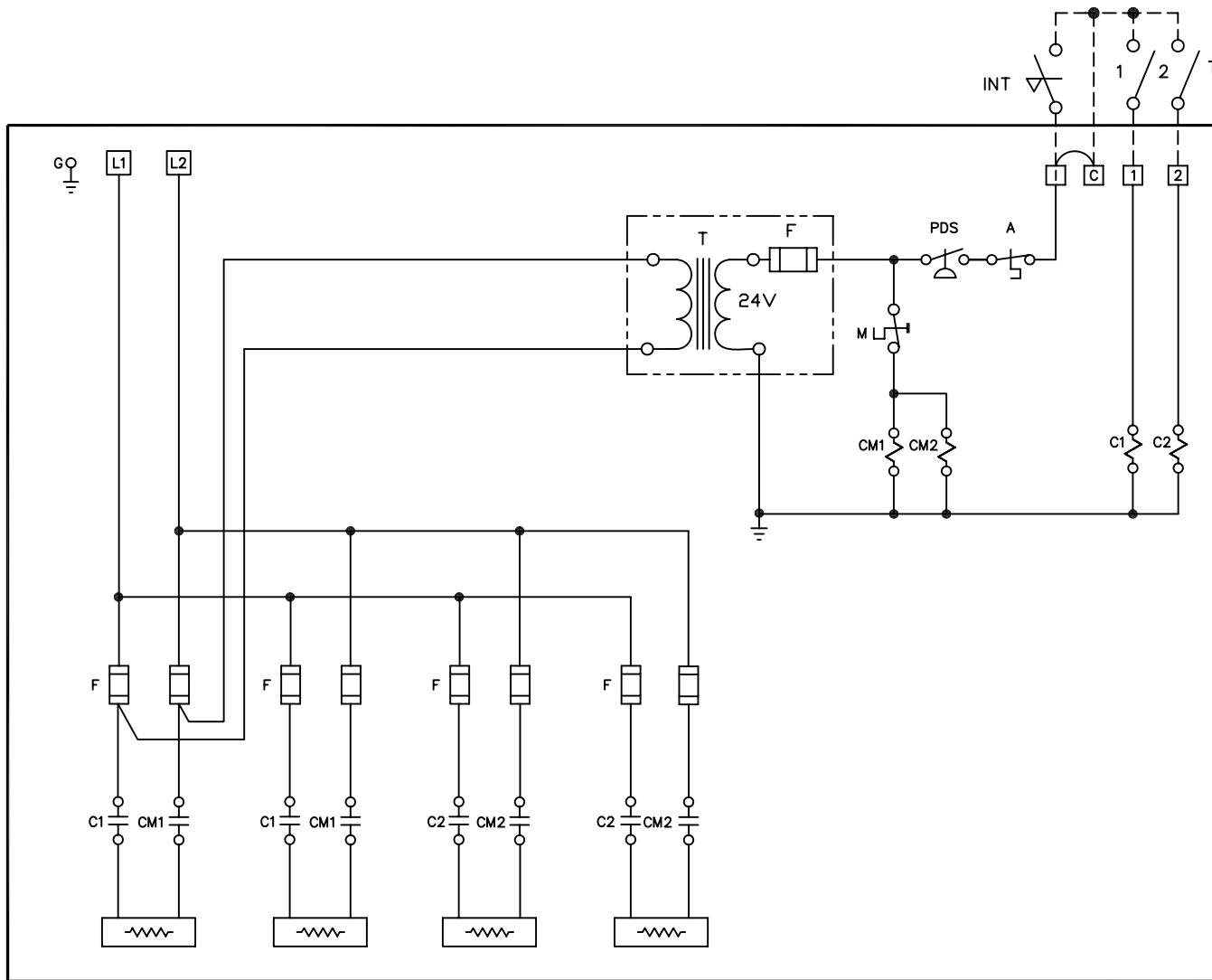

### LEGENDE

- A Sonde thermique à réenclenchement automatique
- C1,C2 Contacteurs de contrôle
- DISC Sectionneur
- F Fusible ou élément fusible
- INT Circuit de verrouillage (si nécessaire)
- M Sonde thermique à réenclenchement manuel
- PDS Interrupteur à différentiel de pression
- T Transformateur de contrôle
- TH Thermostat

### LEGEND

- A Automatic reset thermal cut-out
- C1,C2 Control contactors
- DISC Disconnect switch
- F Fuse or fusible link
- INT Interlock circuit (if needed)
- M Manual reset thermal cut-out
- PDS Pressure differential switch
- T Control transformer
- TH Thermostat

### IMPORTANT

Enlever le pont entre les bornes I & C avant de connecter le circuit de verrouillage.

Faire le câblage suivant les codes nationaux et locaux.  
Lire attentivement les instructions avant de câbler et d'utiliser l'appareil.

Le Serpentin Thermolec est représenté par un cadre en gros trait.  
Tout câblage en dehors du cadre est un "câblage typique fait par d'autres".

### IMPORTANT

Remove jumper between terminals I & C before connecting the interlock circuit.

Wire in accordance with National and local codes.  
Read the instructions carefully before wiring and operating the unit.

The frame in bold line represents the Thermolec Heater.  
All wiring outside this frame is "typical wiring by others".

part no.	description	CFM	Wattage	Amp
<u>TD Series</u>		high / low	high / low	
TD-150	6"/150MM inline mixed flow duct fan (MA 250)	293 / 218	65 / 54	0.54
TD-200	8"/200MM inline mixed flow duct fan (MA500)	538 / 476	184 / 139	0.8
TD-250	10"/250MM inline mixed flow duct fan (MA 700)	754 / 541	255 / 168	2.2
TD-315	12.4"/315MM inline mixed flow duct fan (MA 950)	1050 / 751	347 / 226	2.3
<u>Power Vent Series</u>				
PV-355	14"/inline centrifugal duct fan (MA 1350)	1542	380	3.3

# MIXVENT series

## Dimensions inches/mm

### Models 100-315

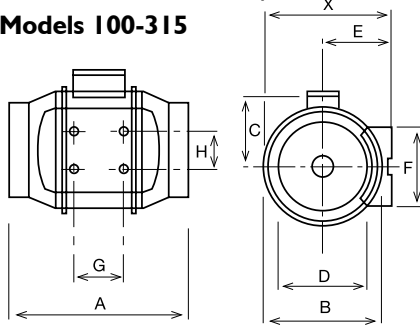

### Models 355 & 400

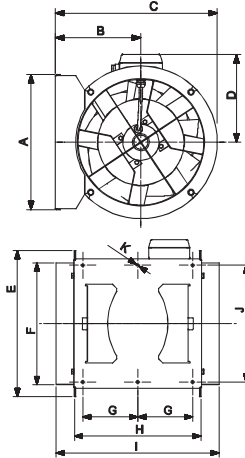

Model	X	A	B	C	D	E	F	G	H
TD-100	5 <sup>15/16</sup> 151	9 <sup>1/8</sup> 232	5 <sup>7/16</sup> 138	3 <sup>3/4</sup> 96	3 <sup>7/8</sup> 98	3 <sup>1/4</sup> 82	3 <sup>3/4</sup> 95	1 <sup>7/8</sup> 48	2 <sup>1/16</sup> 52
TD-100x	7 <sup>3/8</sup> 188	11 <sup>15/16</sup> 303	6 <sup>15/16</sup> 176	4 <sup>1/2</sup> 115	3 <sup>13/16</sup> 97	3 <sup>15/16</sup> 100	3 <sup>9/16</sup> 90	3 <sup>1/8</sup> 80	2 <sup>3/8</sup> 60
TD-125	7 <sup>3/8</sup> 188	10 <sup>3/16</sup> 258	6 <sup>15/16</sup> 176	4 <sup>1/2</sup> 115	4 <sup>13/16</sup> 123	3 <sup>15/16</sup> 100	3 <sup>9/16</sup> 90	3 <sup>1/8</sup> 80	2 <sup>3/8</sup> 60
TD-150	8 <sup>3/8</sup> 212	11 <sup>5/8</sup> 295	7 <sup>7/8</sup> 200	5 127	5 <sup>13/16</sup> 147	4 <sup>7/16</sup> 112	5 <sup>1/8</sup> 130	3 <sup>1/8</sup> 80	2 <sup>3/8</sup> 60
TD-200	9 <sup>3/16</sup> 233	11 <sup>7/8</sup> 302	8 <sup>9/16</sup> 217	5 <sup>9/16</sup> 141	7 <sup>13/16</sup> 198	4 <sup>7/8</sup> 124	5 <sup>1/2</sup> 140	3 <sup>15/16</sup> 100	3 <sup>11/16</sup> 94
TD-200x	9 <sup>3/16</sup> 233	11 <sup>7/8</sup> 302	8 <sup>9/16</sup> 217	5 <sup>9/16</sup> 141	7 <sup>13/16</sup> 198	4 <sup>7/8</sup> 124	5 <sup>1/2</sup> 140	3 <sup>15/16</sup> 100	3 <sup>11/16</sup> 94
TD-250	11 <sup>7/16</sup> 291	15 <sup>3/16</sup> 386	10 <sup>11/16</sup> 272	7 <sup>9/16</sup> 192	9 <sup>3/4</sup> 248	6 <sup>1/8</sup> 155	6 <sup>5/8</sup> 168	5 <sup>11/16</sup> 145	5 <sup>1/2</sup> 140
TD-315	14 356	17 <sup>11/16</sup> 450	13 <sup>1/4</sup> 336	8 <sup>13/16</sup> 224	12 <sup>5/16</sup> 312	7 <sup>3/8</sup> 188	8 <sup>1/4</sup> 210	7 <sup>3/16</sup> 182	7 178

Model	A	B	C	D	E	F	G	H	I	J	K
TD-355	14 <sup>5/16</sup> 377	9 <sup>3/8</sup> 238	17 <sup>3/4</sup> 451	8 <sup>5/16</sup> 224	16 <sup>7/9</sup> 426	13 <sup>8/9</sup> 354	5 <sup>8/9</sup> 150	14 <sup>1/2</sup> 368	18 <sup>2/3</sup> 474	13 <sup>3/8</sup> 340	1/3 8.5
TD-400	1/6 407	9 <sup>4/5</sup> 249	19 <sup>3/8</sup> 492	10 <sup>1/2</sup> 267	19 <sup>1/6</sup> 487	15 <sup>5/7</sup> 399	6 <sup>2/7</sup> 160	16 <sup>3/4</sup> 425	21 <sup>5/9</sup> 547	14 <sup>4/7</sup> 370	1/3 8.5

## Performance

Model	Nom. RPM	Volts	Max. Watts	Speed	CFM v Static Pressure (SP) Ins. WG						Max. SP	Duct Dia. Ins.	
					0"	0.125"	0.25"	0.375"	0.5"	0.75"			1.0"
TD 100	2431	115	23	LS	97	81	51	16	-	-	-	0.4	4"
	2516	115	26	HS	101	85	57	19	-	-	-	0.5	4"
TD 100x	1556	115	20	LS	100	77	48	-	-	-	-	0.4	4"
	2096	115	33	HS	135	113	90	53	-	-	-	0.6	4"
TD 125	1633	115	24	LS	149	110	73	-	-	-	-	0.4	5"
	2146	115	38	HS	197	168	133	86	22	-	-	0.6	5"
TD 150	1709	115	54	LS	218	193	163	128	105	24	-	0.9	6"
	2289	115	65	HS	293	273	250	227	206	131	35	1.2	6"
TD 200	2322	115	139	LS	476	422	373	317	260	40	-	0.9	8"
	2781	115	184	HS	538	495	458	418	367	190	10	1.0	8"
TD 200x	1935	115	122	LS	419	393	363	327	295	215	107	1.2	8"
	2467	115	169	HS	478	457	432	402	372	285	192	1.3	8"
TD 250	2400	115	162	LS	541	475	418	355	295	218	170	2	10"
	3200	115	241	HS	754	715	680	640	606	520	405	2.5	10"
TD 315	2000	115	208	LS	751	670	545	420	285	190	130	1.6	12.4"
	2500	115	335	HS	1050	990	932	850	770	600	420	2.9	12.4"
TD-355	1400	115	464	-	1829	1740	1620	1530	1450	1190	-	1.1	14"
TD-400	1400	115	756	-	2630	2490	2360	2240	2100	1750	350	1.2	16"

Performance certified for installation type D-Ducted inlet, Ducted outlet. Performance ratings do not include the effects of appurtenances (accessories). Speed (RPM or RPS) shown is nominal. Performance is based on actual speed of test.

## Sound

Fan sound levels are measured in sones. At this time there are no sone level test standards available through HVI due to the fact that remote mounted fan noise levels are in proportion to the following: type of duct, length of duct, fan distance from the intake source and other random factors. It is generally accepted that remote mounted venting is usually quieter than standard (in room) venting.



Soler & Palau USA  
6393 Powers Avenue  
Jacksonville, FL 32217  
800.961.7370  
800.961.7379  
www.solerpalau-usa.com

Soler & Palau Canada  
61 A Baywood Road  
Toronto, ON M9V 3Y8  
866.733.0233  
866.358.5346  
www.solerpalaucanada.com

## Distributed By:



Soler & Palau USA certifies that the TD range shown herein is licensed to bear the AMCA Seal. The ratings shown are based on tests and procedures performed in accordance with AMCA Publication 211 and comply with the requirements of the AMCA Certified Ratings Program.



The TD-MIXVENT Series fans are California Title 24 compliant and meet ASHRAE 62.2 when installed with 3 way switch and remotely mounted speed control.

LS = Low Speed  
HS = High Speed

# MOTORIZED DAMPER

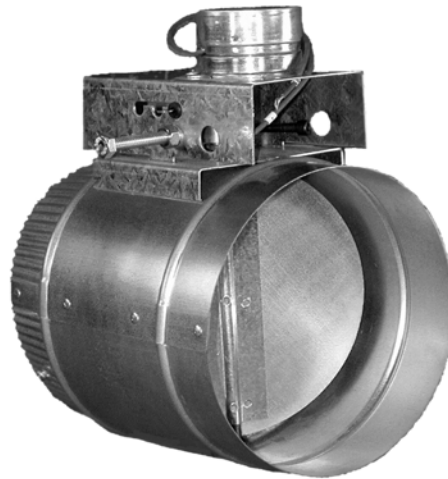

## **THE PREFERRED DAMPER FOR ZONE CONTROL OR FRESH AIR INTAKE.**

- ◆ High Torque Motor for reliable operations time after time. (24V or 120V)
- ◆ Return Spring Assembly provides the strongest return under load.
- ◆ Adjustable flow control standard on all models (N/A with endswitch).
- ◆ Positive closure provides extremely tight seal.
- ◆ Floating Motor mount assures proper alignment of motor, shaft and damper to prevent binding thereby giving greater life expectancy.
- ◆ Combined clutch/coupler reduces number of moving parts.
- ◆ Endswitch available on request.



---

***FRESH AIR MANUFACTURING CO.***

*Technologies in Ventilation*

649 N. Ralstin St., Meridian, ID 83642 \* (208)884-8931 \* 800-234-1903 \* FAX: (208)884-8943

# MOTORIZED DAMPER



## OPTIONS:

- ◆ 24V or 120V models available
- ◆ Normally open or normally closed
- ◆ With or without End Switch

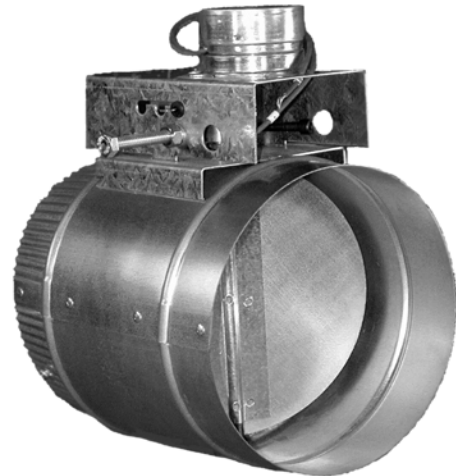

SPRING RETURN DAMPER		
SIZE	NORMAL OPEN	NORMAL CLOSED
4"	ADO 4	ADC 4
5"	ADO 5	ADC 5
6"	ADO 6	ADC 6
7"	ADO 7	ADC 7
8"	ADO 8	ADC 8
10"	ADO 10	ADC 10
12"	ADO 12	ADC 12
14"	ADO 14	ADC 14
16"	ADO 16	ADC 16
18"	ADO 18	ADC 18

SPRING RETURN DAMPER SPEC'S									
DIAM-ETER	4"	5"	6"	7"	8"	10"	12"	14"	16"
Max. Height (with motor)	7"	8"	9"	10"	11"	13"	15"	17"	19"
Max. Motor Height	3"								
Max. Length	6"	6"	6"	7"	8"	10"	12"	14"	16"



**FRESH AIR MANUFACTURING CO.**  
Technologies in Ventilation

# ROUND FILTER BOXES

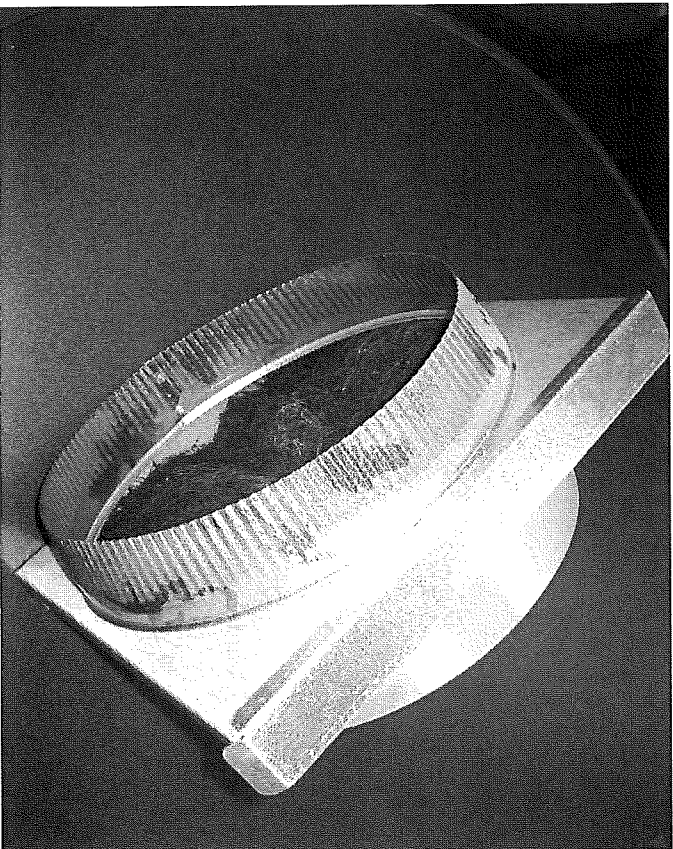

6" INR      7 <sup>1</sup>/<sub>4</sub> X 7 <sup>1</sup>/<sub>4</sub> X 1 <sup>1</sup>/<sub>2</sub>

8" INR      9 <sup>1</sup>/<sub>4</sub> X 9 <sup>1</sup>/<sub>4</sub> X 1 <sup>1</sup>/<sub>2</sub>

10" INR     11 <sup>1</sup>/<sub>4</sub> X 11 <sup>1</sup>/<sub>4</sub> X 1 <sup>1</sup>/<sub>2</sub>

12" INR     13 <sup>1</sup>/<sub>4</sub> X 13 <sup>1</sup>/<sub>4</sub> X 1 <sup>1</sup>/<sub>2</sub>

14" INR     15 <sup>1</sup>/<sub>4</sub> X 15 <sup>1</sup>/<sub>4</sub> X 1 <sup>1</sup>/<sub>2</sub>

## Current Sensing Relay Instructions



*For use in interlocking exhaust fan to EPS Make Up Air Kit*

Please Note: Make sure to check the amp rating of the exhaust fan prior to wiring the current sensing relay. If the amp draw is lower than the sensor's trip rating then multiple loops through the sensor may be required (see figure 1 below) in order for the sensor to work properly. Test the make up air kit to ensure that the sensor is properly calling on make up air kit before putting kit in to full time service

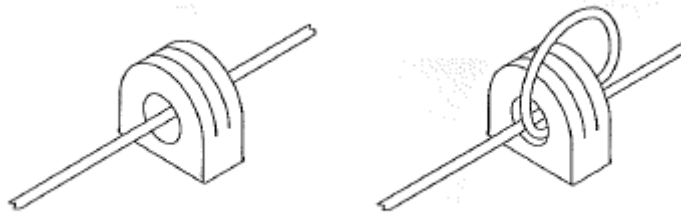

**Figure 1**